

# The Impact of Human Resource Management and Work Climate on Organizational Performance

Garry A. Gelade  
Business Analytic Ltd

Mark Ivery  
Lloyds TSB

## Abstract

*This paper examines relationships between human resource management (HRM), work climate and organizational performance in the branch network of a retail bank. It extends previous research on group-level climate-performance and HRM-performance relationships and examines how climate and HRM function as joint antecedents of business unit performance. Significant correlations are found between work climate, human resource practices, and business performance. The results show that the correlations between climate and performance cannot be explained by their common dependence on HRM factors, and that the data are consistent with a mediation model in which the effects of HRM practices on business performance are partially mediated by work climate.*

Few organizations can evaluate their performance accurately by averaging the performance of their employees. In most cases, the performance of an organization is determined by the productivity and efficiency of such higher-level organizational entities as departments, retail outlets, plants, or teams. In the language of operations research, these productive entities are called 'decision-making units' (DMU's). DMU's can be compared with each other when they consume the same type of resources and produce the same type of outputs. Examples of DMU's within an organization are branches of a bank, stores in a retail chain, or assembly lines in a factory. At a higher level, whole organizations in the same industry can also be treated as DMU's.

Despite the practical importance of DMU performance for managing organizations, research on the psychology of work effectiveness has historically been focused on performance outcomes at the individual employee, rather than at the DMU, level. Thus in a recent meta-analysis of job attitudes and performance, Judge, Thoreson, Bono

and Patton (2001) were able to locate 1,008 individual level studies. Although there can be little doubt that high levels of individual effectiveness are an essential component of superior DMU performance, it is nevertheless clear that a description limited to the individual level is incomplete. Many types of organizational behaviour (e.g. social loafing Shepperd, 1993), and many indicators of organizational performance (e.g. customer satisfaction) exist only at the group level and have no obvious equivalent at the individual level.

Nor can the antecedents of effective group-level performance be inferred solely from individual level antecedents. Consider for example a sales outlet whose customers and whose employees have either Spanish or English as their native language. Under a bonus scheme that rewards individual sales performance, an English-speaking salesperson may be tempted to close a sale with a Spanish-speaking customer to increase their bonus, instead of passing the customer to a Spanish-speaking colleague who might have a

better chance of making the sale. In this example, an incentive scheme that may be highly effective for individual sales-people working on their own serves to depress performance at the DMU level.

It seems reasonable to suppose that DMU performance is a function both of individual employee performance, and the higher-level context in which the jobs are done. However, relatively little is known about DMU performance and its antecedents, and both Ostroff (1992, p. 969), and Ryan, Schmit, and Johnson (1996, p. 878) have argued for more research at this level of analysis. To date, two broad strands of empirical research have emerged.

First, a number of researchers have found links between psychological measures of the work environment (climate, perceptions, attitudes, satisfaction), and performance at the DMU level. For example, Ostroff (1992) demonstrated that school-average levels of teacher satisfaction, commitment, adjustment and stress were correlated with school effectiveness as measured by student achievement, attendance and drop-out rates. Likewise, West, Smith, Feng, and Lawthom (1998) found links between staff perceptions of climate and the research excellence of university departments. Similar relationships have also been found in commercial organizations. For instance, at the level of the whole organization, Kotter and Heskett (1992) showed that the perceived strength of a company's culture is positively correlated with its long-term economic performance as measured by net income growth, return on investment and increase in stock price over a ten year period.

One aspect of DMU performance that has attracted particular attention from organizational researchers is customer satisfaction. Schneider for instance has demonstrated that employees' perceptions of climate correlate with customers' ratings of satisfaction in bank branches (e.g. Schneider & Bowen, 1985; Schneider, Parkington, & Buxton, 1980, Schneider, White, & Paul, 1998). Other authors reporting similar findings include Johnson (1996), Koys (2001), Rucci, Kirn, and Quinn (1998), Ryan, Schmit, and Johnson (1996), and Schmit and Allscheid (1995). Other indicators of DMU performance have also been linked to employee attitudes and climate perceptions. For example reduced staff turnover and superior financial performance are associated with positive attitudes (Ryan, Schmit, & Johnson, 1996), and sales performance with service climate (Borucki & Burke, 1999). Finally, Harter, Schmidt, and Hayes (2002) have shown weak, but meta-analytically generalizable, correlations at the DMU level between customer satisfaction, productivity, profit, staff turnover and accidents, and a composite index of employee satisfaction and engagement.

This body of research is not without its weaknesses; some studies have used small numbers of DMU's (e.g. Koys, 2001,  $n = 28$ ; Schneider & Bowen, 1985,  $n = 28$ ; Schneider, Parkington, & Buxton, 1980,  $n = 23$ ), and some of the most frequently cited (e.g. Kotter & Heskett, 1992; Rucci, Kirn, & Quinn, 1998; Wiley, 1996) have not appeared in peer-reviewed journals. Nevertheless, and despite some negative findings (e.g., Schneider & Snyder, 1975), the evidence to date suggests a reasonably consistent relationship between DMU performance and DMU aggregate measures of both employee satisfaction and work climate.

In this paper, we shall focus on work climate rather than satisfaction. Although these two constructs are conceptually distinct (James & James, 1989; Kopelman, Brief, & Guzzo, 1990), from a measurement perspective they do exhibit considerable overlap; for example, at the individual level, James and James (1989) report an average correlation of .89 between overall job satisfaction and psychological climate. Overall therefore, prior research points both directly and indirectly to the conclusion that DMU's with favorable work climates outperform those with unfavorable climates.

A second strand of research has investigated HRM (human resource management) factors as potential antecedents of DMU performance. For instance, Arthur (1994) found that steel mills operating commitment-centred HRM systems have higher productivity, lower scrap rates, and lower employee turnover than those with control-centred HRM systems. Furthermore, Huselid (1995) found that HRM practices such as employee recruitment and selection procedures, compensation and performance management systems, employee involvement, and employee training have a significant impact on employee turnover and productivity, and on short and long term corporate financial performance. Similarly, Huselid, Jackson, & Schuler (1997) showed that HRM effectiveness is associated with increased financial performance as indexed by productivity, cash flow, and market value. Youndt, Snell, Dean, and Lepak, (1996) showed that, particularly in the context of a quality manufacturing strategy, employee productivity is higher in manufacturing plants where the HRM system is focused on enhancing human capital, and similarly, Patterson and West (1998) found significant influences of job design and employee skill development on the productivity and profitability of small and medium sized UK manufacturing companies.

In summary, the empirical evidence to date points to two distinct correlates of enhanced DMU performance - favorable work climates, and progressive HRM policies and practices. Given that DMU performance is associated both with

work climate and HRM factors, we may envisage two conceptual models. On the one hand, progressive HRM practices may enhance both climate perceptions and business performance. This raises the possibility that the observed associations between climate and performance are spurious (dependent on a common third factor) and thus that climate and performance are not causally connected. A second possibility, proposed by Kopelman, Brief, and Guzzo (1990), Huselid (1995), Delaney and Huselid (1996), and Ostroff and Bowen (2000) among others, is that climate is a mediating link between HRM and performance. The conjecture here is that progressive HRM practices foster a positive work climate, which increases employee well-being and motivation, and this in turn leads to enhanced DMU performance. A conceptual model of this process has been described by Kopelman, Brief, and Guzzo (1990). In their model of organizational functioning, these authors argue that HRM practices designed to improve productivity also influence one or more dimensions of work climate, conceived of here as "meaningful interpretations of a work environment by the people in it." (p. 290). For example, changes in pay and promotion policies might be expected to alter employee perceptions of reward orientation and possibly of equity and fairness; similarly, the introduction of training programs, a practice that often improves productivity, is likely also to have a positive influence on employee perceptions of task support. Work climate in turn is posited to influence the cognitive and affective states of employees in the workplace, in particular, work motivation and job satisfaction; and these psychological states serve to shape individual behaviours such as job performance and citizenship, which in turn have an effect on organizational productivity and performance. Patterson and West (1998) have presented some empirical evidence for such a mediating role of climate, although the sample size for their mediation tests was rather small (n=37).

As Becker and Gerhart (1996. p. 793) point out, the influence of HRM and DMU performance cannot be explained without identification of suitable intervening variables, and understanding the joint and interacting roles of HRM and climate is therefore a vital element in furthering our understanding of performance at the DMU level of analysis. Our purpose in this paper is thus to clarify the processes by which HRM and climate relate to each other, and to DMU performance, and in this way to evaluate the climate-performance relationship within a broader context of DMU functioning than has hitherto been the case.

The DMU's we shall describe are branch clusters of a UK retail bank, and the performance

measures are staff retention, clerical accuracy, customer satisfaction, and sales performance, all measured at the DMU level.

As sub-units of a single organization, these DMU's follow a central HRM strategy and have many HRM procedures in common. However, there is considerable management discretion at the local level, leading for example to different systems for managing the workload, and different emphases on staff development. It is the outcomes of these operational decisions that we use as indicators of HRM practice in the DMU's. The HRM indicators we shall consider are staffing level (as a proportion of the overall workload), working hours (represented by the proportion of overtime) and professional development (represented by the percentage of staff with customer service qualifications). These operationally defined indicators differ from the indicators of HRM that have been used in many previous studies of HRM and performance. Wright, Garner, Moynihan, Hyeon Jeong Park, Gerhart, and Delery (2001) pointed out that most such studies have used single-respondent survey measures of strategic HRM practice, and demonstrated that such measures contain large amounts of measurement error. They further suggested that studies be conducted "...at different levels of analysis where practices are more uniform and performance measures less distal from the effects of practices". This study conforms with that recommendation by examining DMU's that operate within the common strategic HRM framework of a single organization, and by using HRM measures that reflect local decision-making within that framework.

The study addresses two questions. First, can the observed correlations between climate and DMU performance be explained by their common dependence on HRM decisions? Second, does climate mediate the relationship between HRM decisions and DMU performance?

## Method

### DMU Definition

The DMU for this study was the Branch Director Group (BDG). The BDG is a geographically defined cluster of bank branches, comprising between three and 24 branches ( $\underline{M}$  = 10.7) and employing between 95 and 305 staff ( $\underline{M}$  = 178). A Branch Director, responsible for the local contextualization and implementation of Bank policy, manages each BDG, and business performance is monitored centrally against annually defined targets. The BDG is focused primarily on sales and service, with most transaction processing being carried out elsewhere in specialized centers. The BDG was chosen as the DMU rather than the

branch partly because more performance data were available at this level, but primarily because it is effectively a self-contained business, with profitability and operational management responsibilities vested in the Branch Director. There were 137 BDG's in the sample.

#### BDG HRM and Performance Measures.

The HRM and performance measures described below were provided by the bank. They were all drawn from the bank's existing performance management systems rather than being gathered for the purpose of this investigation.

Staffing Level. Staffing level (actual staff level minus theoretical staff establishment), as a percentage of the theoretical staff establishment, averaged over the period May 2000 to March 2001. The theoretical staff establishment is derived from measures of work throughput, in which standard effort is associated with standard tasks such as opening a new account. The maintenance of appropriate staffing levels is a core responsibility of the Branch Director.

Overtime. The percentage of overtime hours worked per month, averaged over the period May 2000 to March 2001. (For the bivariate and multivariate analyses reported here, a square-root transformation of Overtime was used to improve normality.) Overtime is viewed by the bank as a controllable cost, and is a key part of the Branch Director's responsibilities. Local management are encouraged to minimize overtime.

Professional Development. The percentage of BDG staff certified as competent in the provision of customer service. For customer-facing staff, participation in the certification scheme is voluntary, and certification is obtained through experiential training, which is accredited by an external provider of vocational qualifications. Assessors from the awarding body examine record books kept by the candidates, observe their interactions with customers, and award certification to candidates judged to be fully competent. The bank funds this training scheme and provides the infrastructure, but the development effort is supplied by the candidates.

Sales against Target. Overall personal sector sales in the period January 2001 to April 2001 as a percentage of the target value of sales for that period. Each BDG has a series of targets for sales to personal customers. These are weighted and aggregated to an overall personal sector target that takes into account the expected mix of business in the local area, thus providing a target that is theoretically immune to local market variations and unique to each BDG. Sales Against Target is regarded by senior management and BDG

management as the single most important indicator of success.

Customer Satisfaction. Customer Satisfaction as measured by fully-structured telephone survey. The data were gathered during a 3-month window from January 2001 to March 2001. In the period in question, approximately 300 customers were interviewed per BDG. The interview consisted of a series of questions with Likert scale response options. Responses from customers who have visited their BDG branch in the past month are given a higher weighting in constructing the customer satisfaction score.

Staff Retention. The total number of staff remaining in post in the period April 2000 to March 2001 as a percentage of the average number of staff in post in the period.

Clerical Accuracy. The percentage of a particular information form, judged by top management to be important, completed correctly in the period January 2001 to March 2001.

An index formed from the three HRM measures (Staffing Level, Overtime and Professional Development) had a low internal consistency, and so these measures were not combined. However, a composite measure of overall BDG performance computed by averaging the standardized scores for Sales against Target, Customer Satisfaction, Staff Retention and Clerical Accuracy had a reasonably satisfactory level of reliability (Cronbach Alpha .64) and this measure was used as an index of Overall BDG Performance.

#### Employee Survey

Measures of BDG climate were derived from responses to an employee opinion survey, administered in three waves (February 2000, October 2000 and February 2001), each covering approximately one-third of the bank, and producing returns from respectively 9,215, 7,582 and 8,254 employees, at an overall response rate of 49%. The survey was designed by a commercial survey company to monitor employee opinion, not for the purposes of the present study. Slightly different questionnaires were used in each wave, but there were 155 items common to all three waves, most of which had a five-point Likert response scale.

After eliminating questionnaires from non-BDG staff, and those with more than 20% of questions unanswered, there were 14,390 employee questionnaires available for analysis. The number of questionnaires per BDG ranged between 30 and 284 ( $M = 107$ ). The majority of respondents (72.6%) were female; 75.1% of the respondents were clerical or supervisory staff, 12.5% were managers or assistant managers, 1.3% were senior managers or above, and the remainder were in other grades, or did not indicate their grade.

Construction of Climate Scales

Scale construction was conducted at the individual employee level, and was based on factor analysis of all retained questionnaires. After eliminating items that had low response rates or an inappropriate response scale, there were 149 items suitable for factor analysis. Item responses were scored one to five, higher numbers being associated with more favorable responses.

One problem we encountered was that the questionnaire contained a substantial number of consecutive pairs (and some triplets) of similar items with the same stem. Items in such pairs and triplets were sometimes highly correlated, suggesting a method effect which would produce spurious (i.e. method) factors. We therefore conducted a principal components analysis on the 149 items using the technique of radial parceling (Barrett & Kline, 1981; Cattell & Burdsall, 1975) that we have previously found useful in extracting interpretable factors from this type of questionnaire. In this procedure, the items are first subjected to a parceling algorithm that identifies pairs of items with similar loading patterns in the unrotated component matrix, similarity being assessed by the congruence coefficient. The algorithm proceeds by searching for the pair of loading patterns with the highest congruence and

eliminating this pair from subsequent searches. Searching stops when there are no more pairs of items with a congruence coefficient above a specified minimum. The algorithm then attempts to assign each of the remaining unpaired items to one of the previously constructed item pairs to form an item triplet. Triplets are accepted if the average congruence between pairs of items in the triplet exceeds the specified minimum. The minimum congruence coefficient was set at .75, and in this way, 61 two-item parcels and nine three-item parcels were created, all parcels having a congruence coefficient of .78 or higher. Next, parcel scores for each case were computed by averaging the item scores within each parcel and the parcels were subjected to principal components analysis. This procedure recovered ten components explaining 65.8% of the variance of the parcel correlation matrix. All the components were readily interpretable following Oblimin rotation.

Parcels were assigned to each scale in accordance with the rotated component structure, but ignoring parcels with low loadings (i.e. not belonging to any specific component) or complex loadings (i.e. belonging to more than one component.) Seven components were identified as climate indicators. Scale lengths, scale reliabilities and sample items are presented in Table 1.

Table 1. Scale Reliabilities and Sample Items.

Scale	Scale Length <sup>a</sup>	Cronbach Alpha	Sample Item
Leadership	6	.91	Top management is interested in the well-being of employees.
Local Management	13	.94	My manager does a good job of building teamwork.
Goal Clarity	14	.92	I am sufficiently informed about the quality objectives of my team
Job Enablers	14	.90	The training I have received has prepared me well for the work I do.
Coaching	11	.95	My manager gives me regular feedback on my performance.
Job Challenge	11	.90	My job offers little opportunity to use my abilities <sup>b</sup> .
Rewards	5	.86	Compared with other people in my team, I think I am paid fairly.
General Climate	7	.90 <sup>c</sup>	Not applicable

<sup>a</sup> For General Climate, number of scale scores; for all other scales, number of items. <sup>b</sup> Reverse scored.

<sup>c</sup> Based on the seven subscale scores.

The climate dimensions recovered here may be located within the conceptual spaces of organizational climate described by James and James (1989), and by Kopelman, Brief, and Guzzo (1990). Coaching, Leadership and Local Management cover between them much of the space delineated by James and James's second-order climate factor Leader Support and Facilitation. Goal Clarity would appear to correspond to James and James' first-order factor Role Ambiguity (reversed), and to be part of Kopelman *et al.*'s Goal Emphasis. Rewards clearly

falls within Kopelman *et al.*'s Reward Orientation, and Job Challenge within James and James' second-order factor Job Challenge & Autonomy; Job Enablers can be clearly located within Kopelman *et al.*'s Task Support. However, no dimensions were recovered directly corresponding to James and James' Work Group Co-operation Warmth and Friendliness, or to Kopelman *et al.*'s Means Emphasis or Socioemotional Support.

The average correlation between the scales was .56, and in addition, principal components analysis of the seven scale scores

recovered a single component explaining 64% of the variance of the scale score correlation matrix. This suggests the existence of a higher-order climate factor underlying employee perceptions. This factor appeared to be conceptually equivalent to the General Psychological Climate factor (PCg) identified by James and James (1989). According to these authors, PCg represents all emotionally relevant work-related cognitions and reflects the degree to which the work environment is perceived as personally beneficial or detrimental to one's well-being; evidence for such a hierarchical factor has also been reported by Parker (1999). Accordingly we averaged the scores on the seven first-order scales to create a summary scale which we labeled General Climate (see Table 1).

#### Aggregation

Although organizational climate is measured through individual perceptions, the appropriate unit of analysis is the organization or organizational sub-unit. To obtain climate scores at the appropriate level of analysis, it is thus necessary to aggregate individual employee scores to the group level, and it has been suggested that aggregation is justifiable only if there is a minimum degree of consensus among the respondents in the group (James, 1982; Joyce & Slocum, 1984).

There are several reasons to expect that a degree of consensus might exist at the BDG level. First, employees within a BDG interact with each other. Staff are often directed, either routinely or exceptionally, to work at other branches within their BDG, to cope with temporary peaks in workload or sickness. Furthermore, staff with a common role also attend regular meetings at BDG level, and key events for employees, such as the annual pay awards and major social events, are coordinated at BDG level. It has long been known in

the social sciences that people can and do exert a strong influence on each other's beliefs, attitudes and behaviours (e.g. Allport, 1935; Turner, 1991), and as Sechrist and Stangor (2001) demonstrated, learning whether one's beliefs are or are not shared with others influences attitudes, behaviour, and the strength of the attitude-behaviour relationship. Interactions among staff thus provide a basis for the evolution of commonly held job-related opinions and beliefs among employees within a BDG.

Secondly, differences in BDG local strategies, such as the priority accorded to training, the implementation of workload-sharing systems, and the relative emphasis placed on the sales and service functions, provide opportunities for distinct BDG characteristics to evolve, and suggest that aggregated BDG climate scores would reflect genuine group differences.

Glick (1985) has argued that the best statistic for justifying aggregation is ICC2, the reliability of the mean group score. ICC2 was .88, well above the accepted minimum criterion of .7. In addition, ICC1, the individual level intraclass correlation, was .07, and a maximum-likelihood variance components analysis showed that 7.4% of the variance in climate scores was attributable to the BDG. Overall therefore aggregation to the BDG level seems justified on both substantive and statistical grounds, and accordingly, BDG climate scores were calculated by averaging individual climate scores within each BDG.

## Results

### Univariate Statistics and Bivariate Correlations

Table 2 shows univariate statistics, and bivariate correlations between the study variables.

Table 2. Univariate Statistics and Pearson Product Moment Correlations.

	1	2	3	4	5	6	7	8	9
1 General Climate	1								
2 Sales	.36***	1							
3 Customer Satisfaction	.20*	.26**	1						
4 Clerical Accuracy	.18*	.17*	.22**	1					
5 Staff Retention	.33***	.32***	.57***	.28***	1				
6 Overall Performance	.39***	.63***	.74***	.61***	.78***	1			
7 Staffing level	.20*	.16	.41***	.18*	.39***	.41***	1		
8 Overtime	-.33***	-.17*	-.08	-.17*	-.19*	-.22**	-.38***	1	
9 Professional Development	.18*	.19*	.37***	.18*	.34**	.39***	.08	-.09	1
<u>M</u>	3.3	105.1	71.0	83.1	92.5	0.0	-2.7	1.3	26.9
<u>SD</u>	0.2	11.4	3.2	8.7	4.4	0.7	4.1	0.6	9.1
<u>N</u>	134	136	137	137	137	137	129	137	129

\*  $p < .05$ , \*\*  $p < .01$ , \*\*\*  $p < .001$ . Note: For Overtime, correlations are calculated using the transformed variable, but means and SDs are for the untransformed variable.

The correlations reported in Table 2 are largely in accordance with expectations and with previous research. First, General Climate correlates positively with Sales Against Target, Staff Retention, Clerical Accuracy, Customer Satisfaction, and Overall Performance. This confirms previous research that favorable perceptions of the work environment are associated with elevated DMU performance. Secondly, the results provide additional evidence for the impact of HRM factors on business performance. High levels of Overtime are associated with lower levels of Sales Against Target, Clerical Accuracy, Staff Retention, and Overall Performance; increased Staffing Levels are associated with elevated scores on all performance outcomes except Sales Against Target; and increased levels of Professional Development are associated with enhanced performance on all business outcomes. In addition, all three HRM indicators are significantly correlated with General Climate, a finding consistent with the view that positive HR practices contribute to employees' sense of well-being. Finally, we note that there are significant correlations between the business outcomes, and in particular, correlations between customer satisfaction and sales have also been reported by e.g. Rucci, Kim, and Quinn (1998).

#### HRM-Climate-Performance Relationships

To test the possibility that the observed relationships between climate and performance are due to the common influence of HRM decisions, we computed partial correlations between General Climate and each of the performance outcomes while controlling simultaneously for the three HRM variables Staffing Level, Overtime and Professional Development. The partial correlations ( $df = 121$ ) were respectively: Sales Against Target,  $r = .30$ ,  $p <$

$.001$ ; Clerical Accuracy,  $r = .10$ , ns; Staff Retention,  $r = .24$ ,  $p < .01$ ; Overall Performance,  $r = .30$ ,  $p = .001$ ; Customer Satisfaction,  $r = .12$ , ns. Comparing these correlations with the corresponding zero order correlations in Table 2 we see that of the five significant climate-performance correlations in Table 2, three (Sales Against Target, Staff Retention, and Overall Performance) remain significant, and only the correlations for Clerical Accuracy and Customer Satisfaction become non-significant when the HRM variables are partialled out. This demonstrates that the climate-performance correlations observed here cannot be explained by a common correlation with the HRM variables.

Next, we examined the role of climate as a mediator between each of the three HRM variables and the BDG performance outcomes. In the procedure advocated by Baron and Kenney (1986), mediation effects are determined by analysis of separate regression equations. However, a convenient alternative is to estimate a path model as shown in Figure 1, where the box labelled HRM represents an HRM decision variable, and the box labelled Performance Outcome represents a BDG performance indicator. In this model, the direct effect of the HRM variable on performance is represented by path  $c$ , and the indirect (mediation) effect by paths  $a$  and  $b$ . If  $a$ ,  $b$  and  $c$  are path coefficients, the strength of the mediation effect is  $a*b$ , and the percentage mediation (i.e. mediation effect / total effect) is given by  $a*b/(a*b + c)$ . In the analyses described below, model parameters were derived using the full-information maximum likelihood estimation procedure of the AMOS modelling program (Arbuckle, 1999). This estimation method can handle missing data, so each model was estimated using all 137 BDG's. To ensure the model was identified (solvable), the path coefficients from the error variance components were set to 1 as shown in Figure 1.

Figure 1. Mediation Path Model

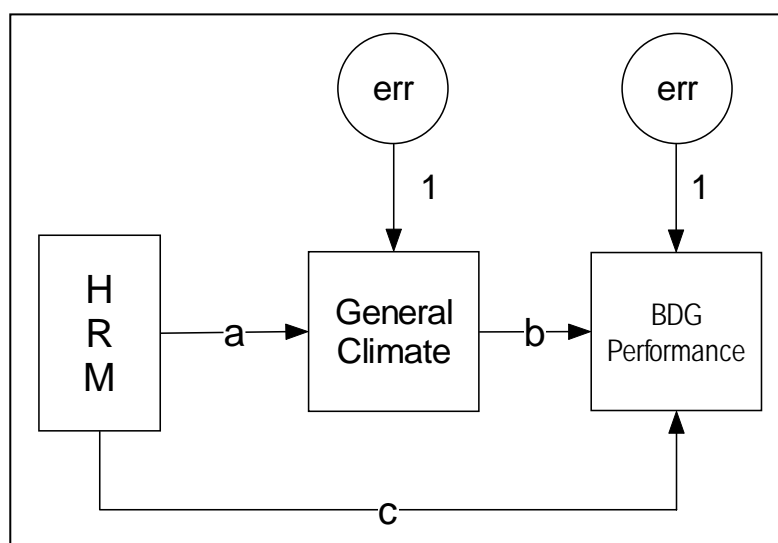

Note: err=Error variance.

Fifteen different path models were estimated (one for each combination of HRM and

performance outcome) and the results are shown in Table 3.

Table 3. Mediation Model Results.

Performance Outcome	HRM Variable	Standardized Path coefficients			% Variance Explained	% mediation <sub>a</sub>
		a	b	c		
Sales	Staffing Level	.19**	.34***	.09	13.4	—
	Overtime	-.33***	.34***	-.06	12.9	65.9***
	Professional Development	.17*	.33***	.13	14.1	31.1*
Customer Satisfaction	Staffing Level	.20**	.13	.38***	18.2	6.1
	Overtime	-.33***	.20*	-.02	4.1	—
	Professional Development	.18*	.14	.36***	16.2	6.5
Clerical Accuracy	Staffing Level	.20**	.15	.15	5.5	16.9
	Overtime	-.33***	.14	-.13	4.8	27.0
	Professional Development	.18*	.16	.15	5.5	15.3
Staff Retention	Staffing Level	.19**	.26***	.34***	21.6	13.1**
	Overtime	-.33***	.30***	-.09	11.5	51.5***
	Professional Development	.17*	.28***	.30***	19.1	13.7*
Overall Performance	Staffing Level	.20**	.32***	.35***	26.3	15.1**
	Overtime	-.33***	.35***	-.11	15.8	52.0***
	Professional Development	.17*	.33***	.34***	25.9	14.3*

\* p <= .05, \*\* p <= .02, \*\*\* p <= .001. N=137

<sub>a</sub> Omitted where correlation between HRM and performance indicator is non-significant.

The first three data columns of Table 3 show the path coefficients for the paths depicted in Figure 1, and the next column shows the percentage of variance in the performance outcome accounted for by the independent variables in the model. This is followed by the percentage mediation, with the significance level for the null hypothesis of no mediation, based on a test of the joint significance of *a* and *b*, which MacKinnon, Lockwood, Hoffman, West, and Sheets (2002) recommend as

yielding the best combination of Type I error rate and statistical power.

The results show that sizeable proportions of the variance in BDG performance can be accounted for by climate and HRM decisions. Using Cohen's classification of effect sizes for the variance explained in a dependent variable (2% small, 13% medium, 26% large; Cohen, 1998, pp. 412-414) the results show that the model explained variance effects for Sales and Staff Retention are

medium, the effects for Customer Satisfaction are small to medium, the effects for Clerical Accuracy are small, and the effects for Overall Performance are medium to large.

In addition, significant mediating effects of work climate were obtained for five of the HRM-climate-performance models using individual performance outcomes, and all three of the models using Overall Performance. Overall these results provide clear support for the role of work climate as a partial mediator between HRM practices and DMU performance.

#### Limitations

The findings of this study should be interpreted within the context of its limitations. First, the observations are of a single organization, and the extent to which they are representative of organizations in general, or even of service organizations in general, can be determined only by reference to the work of other researchers.

Next, what is presumably a causal system has been examined here using cross-sectional data. That is, although the performance indicators post-date the climate and HRM measures, each variable is represented in the data only at a single point in time. This does not necessarily invalidate the conclusions that may be drawn, because time-lagged correlations suggest that BDG performance is reasonably stable. The mean correlations between consecutive quarters for BDG Staffing Level, Overtime and Staff Retention are respectively .78, .71 and .51 ( $df = 137$ ); additionally, the correlation between consecutive two-month periods for Sales Against Target is .65 ( $df = 134$ ), and the correlation between BDG Customer Satisfaction for September 2000 and the first quarter of 2001 is .68 ( $df = 135$ ).

Finally, the mediation model we describe is not the only model that could have been constructed to fit the observed data; it is well-known that a causal model can usually be replaced by one or more equivalent models with identical fit characteristics (Loehlin, 1992, p. 194) and the choice of model rests on substantive and theoretical considerations. The issue of substance here is the directionality of the link between climate and performance; to simplify, does climate cause performance or does performance cause climate? In the present case, reversing the direction of causal flow between climate and performance leads to a theoretically plausible model in which performance is the mediating variable, that is, effective HRM decisions enhance performance, which in turn leads to positive employee attitudes. Cross-sectional data cannot distinguish between these possibilities; longitudinal data is required. However, the evidence from longitudinal studies is mixed. Ryan,

Schmit and Johnson (1996) found that customer satisfaction predicted subsequent employee satisfaction, but that employee satisfaction did not predict subsequent customer satisfaction, evidence that performance causes climate rather than vice-versa. West *et al.* (1998) found that that research ratings predicted subsequent climate in university research departments more strongly than climate predicted subsequent research ratings, concluding that climate was an outcome of performance rather than a cause. On the other hand, Ryan, Schmit, and Johnson (1996) found the direction of the link between morale and productivity to be indeterminate, and more emphatically, Koys (2001) found clear evidence that climate causes performance; specifically, employee satisfaction predicted subsequent customer satisfaction and organizational citizenship behaviour predicted subsequent profits (rather than the other way round). Furthermore, Patterson and West (1998) found that significant relationships between climate, HRM factors and performance remained when prior performance was partialled out.

Thus although alternative models with reversed directionality cannot be conclusively ruled out, the model presented here is not incompatible with the weight of current evidence, and is broadly consistent with previous conceptions of the antecedents of DMU performance, and with the temporal ordering of the variables that were measured.

Finally, we note that the mediation model presented here almost certainly represents a considerable simplification of the complex, and possibly reciprocal, system of causal relationships, that characterize a sophisticated commercial DMU. For example, sales effectiveness may be a consequence of customer satisfaction, which itself may be a consequence of high staff turnover. Furthermore, we might suppose that high levels of turnover may cause chronically low staffing levels, which in turn might lead to increased overtime demands and to a depressed work climate, thus reducing sales effectiveness. We have carried out exploratory structural modelling shows that such a circular system of relationships would indeed be compatible with the observed data.

#### Discussion

Many features of the results described here are consistent with prior research at the DMU level of analysis. However, there are also some differences between this study and prior research on customer satisfaction. Some service researchers have proposed that customers are influenced by the attitudes expressed by the service employees they encounter (e.g., Ulrich, Halbrook, Mecker,

Stucklik, & Thorpe, 1991; Schneider & Bowen, 1992). This supposes that satisfied employees radiate positive affect, producing an emotionally satisfying sales experience for the customer. However, in the present study, the correlation between General Climate and Customer Satisfaction is rather weak, and the strongest correlates of Customer Satisfaction are Staffing Level, Staff Retention and Professional Development. Transfer of affect does not seem to be a wholly satisfactory explanation for these results.

Examination of individual items in the customer satisfaction telephone survey showed that the correlations of Staffing Level with ratings of staff politeness, empathy, friendliness were between .30 and .32, ( $df = 137$ ,  $p < .001$ ), but the strongest correlate of Staffing Level was ease of contact ( $r = .59$ ,  $df = 137$ ,  $p < .001$ ). Thus although customers of understaffed outlets do experience less positive affect, their main source of dissatisfaction seems to be the low levels of responsiveness that such outlets provide.

Staff Retention was the strongest correlate of Customer Satisfaction. One explanation is that in DMU's with high levels of turnover, customers are more likely to encounter inexperienced employees, who are less able to provide an efficient service. Two findings support this view. First, there is a positive correlation between Staff Retention and Professional Development which means that high turnover BDG's have fewer qualified staff. Secondly, high turnover BDG's have lower levels of Clerical Accuracy, an indication of inefficiency. However, the nature of the sales encounter between the customer and employee may moderate the staff turnover-customer satisfaction relationship. Consistent with the present findings, Ryan, Schmit and Johnson (1996) observed a correlation between turnover and customer satisfaction in a financial services organization; but no correlation between turnover and customer satisfaction was observed in either Koys' (2001) study of restaurants, or Rucci, Kirn, and Quinn's (1998) study of a department store. Speculatively, where the relationship between customer and employee has a confidential component, or is of an advisory nature, a satisfying commercial encounter may depend on being recognized by a service employee, or on being served by an employee familiar with the customer's transaction history, as well as professionalism and efficiency. In DMU's with high levels of turnover, established customers are less likely to encounter such employees and may accordingly report reduced levels of satisfaction. In summary, although customer satisfaction levels may be partly determined by affective influences, there are reasons to suppose

that in some circumstances, other factors may be equally, or more, important.

Turning to the joint relationships between HRM, climate and performance, the finding that significant associations between climate and performance remain after partialling out the common effects of HRM supports the conception of a direct relationship between climate and performance which is independent of HRM decisions. Secondly, the mediating effect of climate observed here is consistent with the empirical findings of Patterson and West (1998) and with the suggestions of previous writers that progressive HRM practices influence organizational performance partly by enhancing climate. There are also however strong direct links between HRM decisions and performance that are independent of climate, and which are consistent with expectations. For example, both understaffing and overtime working imply elevated job demand, which is widely accepted to be a potential source of stress and depressed individual performance; conversely, encouragement of professional development is likely to increase individual effectiveness. These factors may underlie the direct links between HRM and DMU performance found here.

The joint role of climate and employee satisfaction as mediators between HRM and performance remains to be established empirically. In the models of Kopelman, Brief, and Guzzo (1990), and by Ostroff and Bowen (2000), satisfaction and motivation are conceived as a mediating link between climate and organizational performance, so that climate is more distal, and employee satisfaction is less distal, to organizational performance. This would seem to be a fruitful avenue for future research, but for the present, we note that the correlations between climate and performance obtained here are noticeably larger than the mean absolute uncorrected value of .13 obtained by Harter, Schmidt and Hayes (2002) for the correlations between a composite index of employee satisfaction and engagement and DMU performance.

### Conclusion

This study builds on previous research showing that favorable psychological environments in the work place, and progressive HRM practices, such as management of job demand and support for professional development, are associated with superior organizational performance. The model of DMU functioning that we have described incorporates climate and HRM outcomes as joint and inter-related antecedents of DMU performance, and accounts for proportions of the variance in

DMU performance that are significant in both statistical and practical terms.

In addition, we found that the relationships between climate and DMU performance cannot be explained by their common dependence on HRM factors. However, the data were compatible with a model in which HRM decisions have both a direct and an indirect influence on performance. In this model, HRM decisions exert their indirect effect by enhancing or depressing the work climate which in turn produces subsequent changes in DMU performance.

Understanding the impact of HRM decisions on employee attitudes and behaviour, and the potential effects on organizational performance, has considerable practical importance for local management as well as for central HR practitioners. In large organizations, where decision-making is partially decentralized, local HRM decisions are often strongly influenced by considerations of their associated operating costs. The cross-sectional relationships demonstrated in the present study provide empirical evidence that HRM decisions, climate and DMU performance are connected, but more research - especially longitudinal research - is required to establish the extent of causality in this domain.

Many organizations routinely collect HRM and performance data and conduct climate or employee attitude surveys, but this information is often compartmentalised at departmental levels. Academic researchers who would like access to this data need to offer clear benefits to participating organizations - for example identification of best and worst practice and recommendations for performance improvement - to compensate for the often considerable effort that is needed to integrate these various data sources. We would recommend close collaboration with psychologists and human resource practitioners working in such organizations who are often well-placed to collate such information, and have an interest in using the outcomes of the analysis to inform their decision-making. If data can be collected on a longitudinal basis, it might prove possible to evaluate HRM decisions in terms of their long-range impact on business performance, rather than just in terms of their immediate impact on operating costs.

#### References

Allport GW. (1935). Attitudes. In Murchison C (Ed.). Handbook of Social Psychology (pp. 798-844). Worcester, MA: Clark University Press.

Arbuckle JL. (1999). AMOS (Version 4.01). Chicago, IL: SmallWaters Corp.

Arthur JB. (1994). Effects of human resource systems on manufacturing performance and turnover. Academy of Management Journal, 37, 670-687.

Barrett P, Kline, P. (1981). Radial parcel factor analysis. Personality and Individual Differences, 2, 311-318.

Becker B, Gerhart, B. (1996). The impact of human resource management on organizational performance: progress and prospects. Academy of Management Journal, 39, 779-801.

Borucki CC, Burke MJ. (1999). An examination of service-related antecedents to store performance. Journal of Organizational Behavior, 20, 943-962.

Cattell RB, Burdsall JR. (1975). The radial parcel double factoring design: A solution to the item vs parcel controversy. Multivariate Behavioral Research, 10, 165-179.

Cohen J. (1988). Statistical power for the behavioral sciences. Hillsdale, NJ: Erlbaum.

Delaney JT, Huselid MA. (1996). The impact of human resource management practices on perceptions of organizational performance. Academy of Management Journal, 39, 949-969.

Glick WH. (1985). Conceptualising and measuring organizational and psychological climate: Pitfalls in multi-level research. Academy of Management Review, 10, 606-616.

Harter JK, Schmidt F L, Hayes TL. (2002). Business-unit-level relationship between employee satisfaction, employee engagement, and business outcomes: A meta-analysis. Journal of Applied Psychology, 87, 268-279.

Huselid MA. (1995). The impact of human resource management practices on turnover, productivity, and corporate financial performance. Academy of Management Journal, 38, 635-672.

Huselid MA, Jackson SE, Schuler RS. (1997). Technical and strategic human resource management effectiveness as determinants of firm performance. Academy of Management Journal, 40, 171-188.

James LR. (1982). Aggregation bias in estimates of perceptual measures. Journal of Applied Psychology, 67, 219-229.

James LA, James LR. (1989). Integrating work environment perceptions: Exploration into the Measurement of Meaning. Journal of Applied Psychology, 74, 739-751.

Johnson JW. (1996). Linking employee perceptions of service climate to customer satisfaction. Personnel Psychology, 4, 831-851 .

Joyce VF, Slocum JW. (1984). Collective climate: agreement as a basis for defining aggregate

- climate in organizations. Academy of Management Journal, 27, 721-742.
- Judge TA, Thoreson CJ, Bono JE, Patton GK. (2001). The job satisfaction-job performance relationship a qualitative and quantitative review. Psychological Bulletin, 127, 376-407.
- Kotter JP, Heskett JL. (1992). Corporate Culture and Performance. New York: The Free Press.
- Kopelman RE, Brief AP, Guzzo RA. (1990). The role of climate and culture in productivity. In Schneider B. (Ed.). Organizational Climate and Culture. San Francisco, CA: Jossey-Bass.
- Koys DJ. (2001). The effects of employee satisfaction, organizational citizenship behaviour and turnover on organizational effectiveness: A unit-level, longitudinal study. Personnel Psychology, 54, 101-114.
- Loehlin JC. (1992). Latent Variable Models, 2<sup>nd</sup> ed., Hillsdale, NJ: Lawrence Erlbaum.
- MacKinnon DP, Lockwood CM, Hoffman JM, West SG, Sheets V. (2002). A comparison of methods to test mediation and other intervening variables effects. Psychological Methods, 7, 83-104.
- Ostroff C. (1992). The relationship between satisfaction, attitudes, and performance: An organizational level analysis. Journal of Applied Psychology, 77, 963-974.
- Ostroff C, Bowen DE. (2000). Moving HR to a higher level. In Klein KJ, Kozlowski SWJ (Eds.). Multilevel Theory, Research, and Methods in Organizations. (pp. 211-265). San Francisco, CA: Jossey-Bass Wiley.
- Parker CP. (1999). A test of alternative hierarchical model of psychological climate: PCg, satisfaction or common method variance? Organizational Research Methods, 2, 257-274.
- Patterson MG, West MA. (1998). Human resource management practices, employee attitudes and company performance. Proceedings of the 1<sup>st</sup> International Work Psychology Conference. Sheffield, UK: University of Sheffield Institute of Work Psychology.
- Rucci AJ, Kirn SP, Quinn RT. (1998). The employee-customer-profit chain at Sears. Harvard Business Review, Jan-Feb, 83-97.
- Ryan AM, Schmit, MJ, Johnson R. (1996). Attitudes and effectiveness: Examining relations at an organizational level. Personnel Psychology, 49, 853-882.
- Schmit MJ, Allscheid SP. (1995). Employee attitudes and customer satisfaction: Making theoretical and empirical connections. Personnel Psychology, 48, 521-535.
- Schneider B, Bowen D. (1985). Employee and customer perceptions of service in banks: Replication and extension. Journal of Applied Psychology, 70, 423-433.
- Schneider B, Bowen DE. (1992). Personnel/human resources management in the service sector. In Ferris GR, Rowland KM (Eds.). Research in personnel and human resources management (Vol. 10, pp. 1-30). Greenwich, CT:JAI.
- Schneider B, Parkington J, Buxton V. (1980). Employee and customer perceptions of service in banks. Administrative Science Quarterly, 25, 252-267.
- Schneider B, Snyder RA. (1975). Some relationships between job satisfaction and organizational climate. Journal of Applied Psychology, 60, 318-328.
- Schneider B, White SS, Paul MC. (1988). Linking service climate and customer perceptions of service quality: Tests of a causal model. Journal of Applied Psychology, 83, 150-163.
- Sechrist GB, Stangor C. (2001). Perceived consensus influences intergroup behavior and stereotype accessibility. Journal of Personality & Social Psychology, 80, 645-654.
- Shepperd JA. (1993). Productivity loss in performance groups: A motivation analysis. Psychological Bulletin, 113, 67-81.
- Turner JC. (1991). Social influence. Pacific Grove, CA: Brooks/Cole.
- Ulrich D, Halbrook R, Mecker D, Stucklik M, Thorpe S. (1991). Employee and customer attachment: synergies for competitive advantage. Human Resources Planning, 14, 89-103.
- West MA, Smith H, Feng WL, Lawthorn R. (1998). Research excellence and departmental climate in British universities. Journal of Occupational and Organizational Psychology, 71, 261-281.
- Wiley JW. (1996). Linking survey results to customer satisfaction and business performance. In Kraut AI (Ed.). Organizational Surveys: Tools for Assessment and Change. San Francisco, CA: Jossey-Bass.
- Wright PM, Garner TM, Moynihan LM, Hyeon Jeong Park, Gerhart B, Delery JE. (2001). Measurement error in research on human resources and firm performance: additional data and suggestions for further research. Personnel Psychology, 54, 875-901.
- Youndt MA, Snell SA, Dean JW Jr., Lepak, DP. (1996). Human resource management, manufacturing strategy, and firm

PERSONNEL PSYCHOLOGY  
2003, 56, 383-404

performance. Academy of Management Journal, 39, 836-866 .